

# MANUFACTURING ACTIVITY BOOK

*Batesville Products, Inc.*



With coloring pages  
from the children's  
book *Foundry Friends*  
*Make a Casting!*



# ENGINEERING



# FINISH THE BLUEPRINT

Oh no! The engineer lost the blueprint for making a new toy! Can you help him draw the toy, so that he can build a mold? Connect the dots to finish the blueprint!

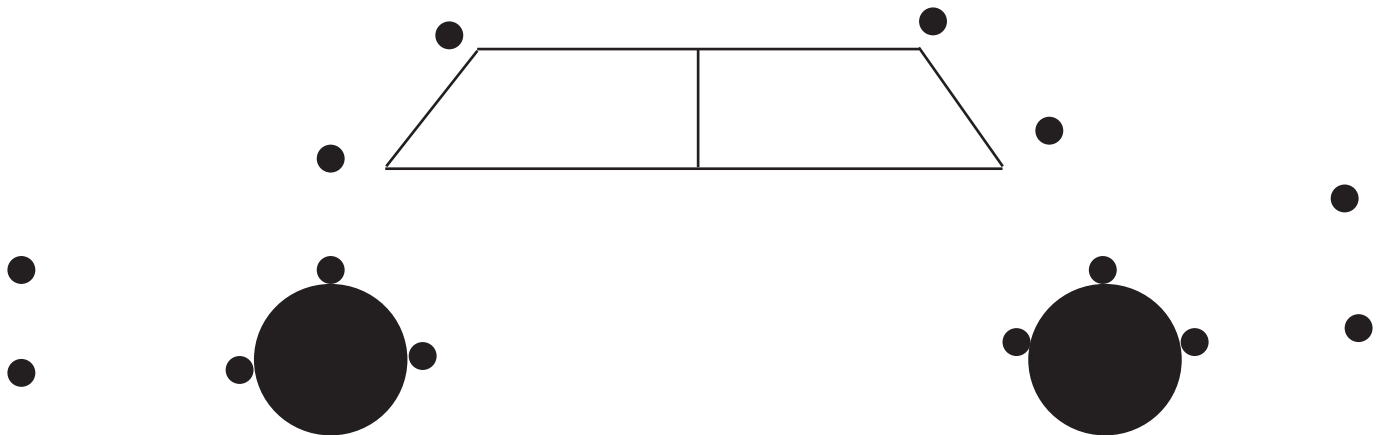

*color me!* 

## ***What's a blueprint?***

A blueprint is a detailed drawing that plans how an object will be made. Blueprints have lots of measurements!



# FINISH THE BLUEPRINT

Oh no! The engineer's blueprints were ripped in half! Use your drawing skills to finish the blueprints.

## ***What's a blueprint?***

A blueprint is a detailed drawing that plans how an object will be made. Blueprints have lots of measurements!

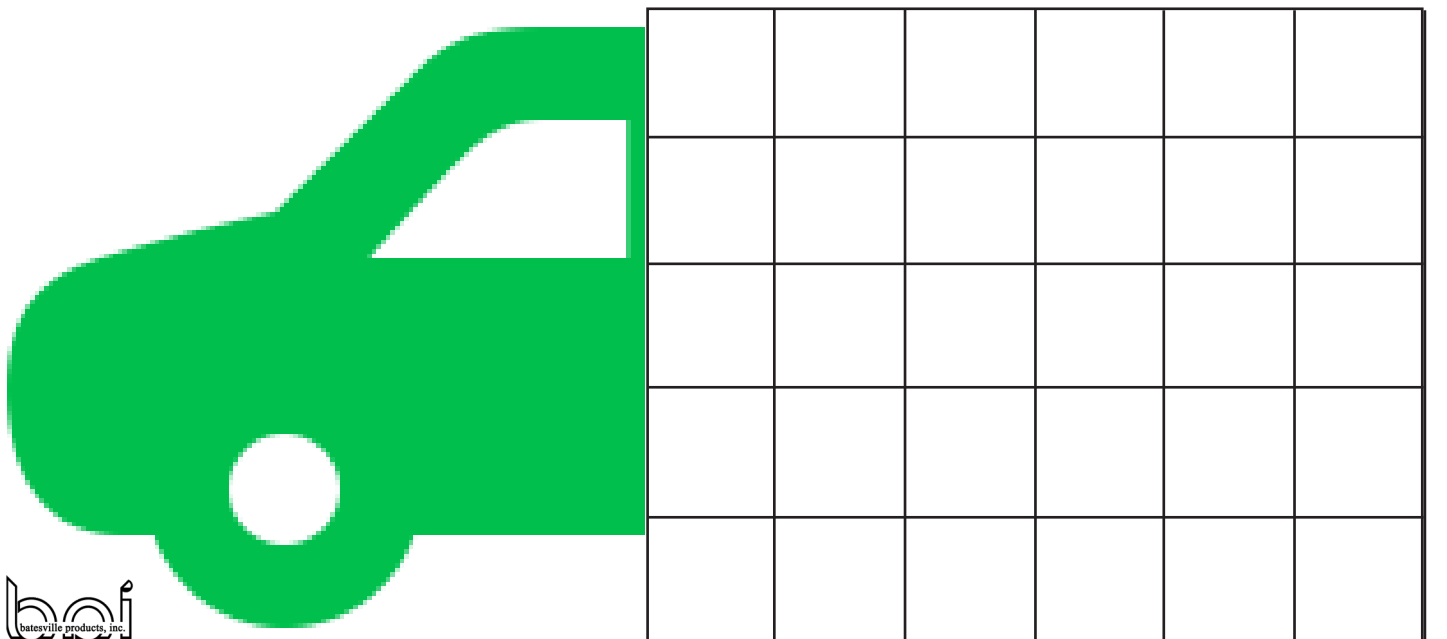
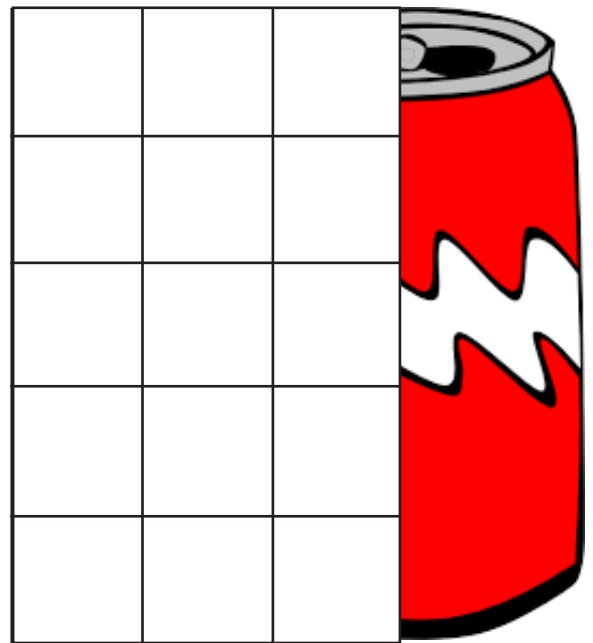





© Batesville Products, Inc.

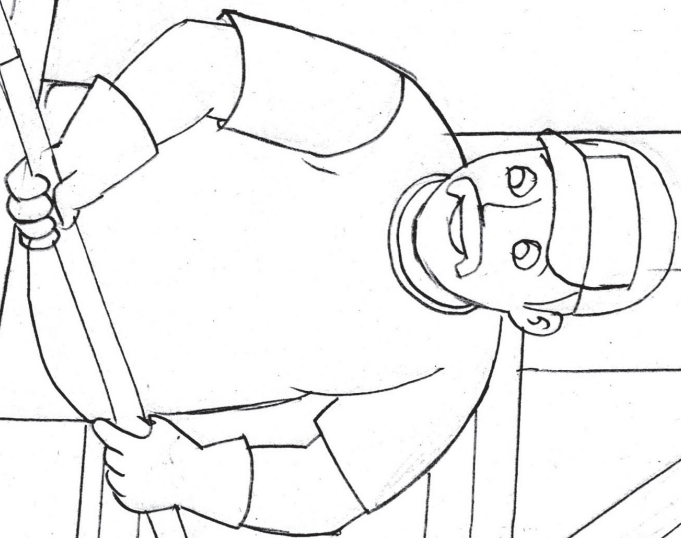
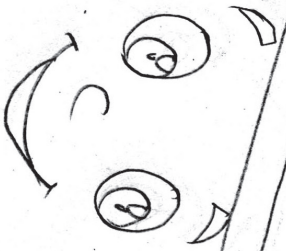

# CASTING

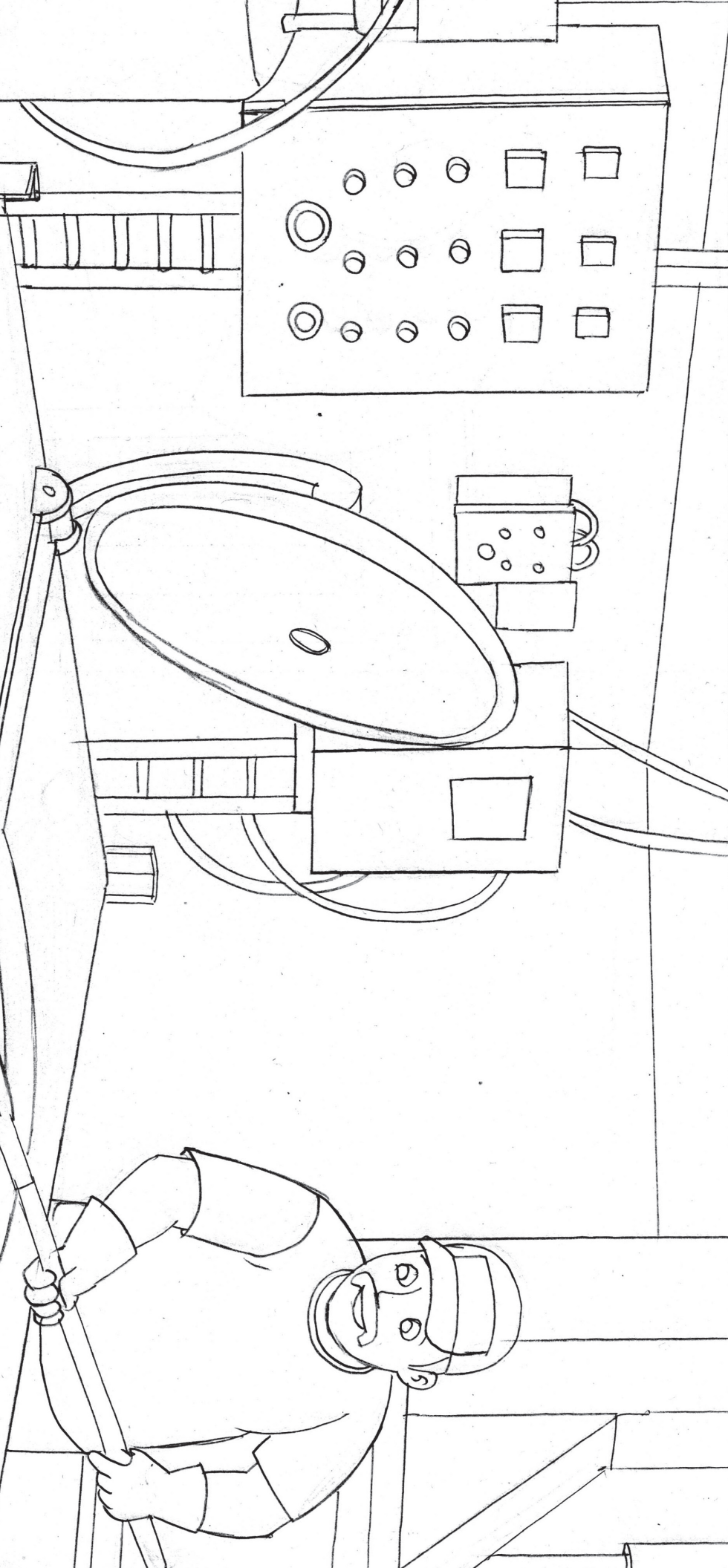

# WORD SEARCH

Level 1

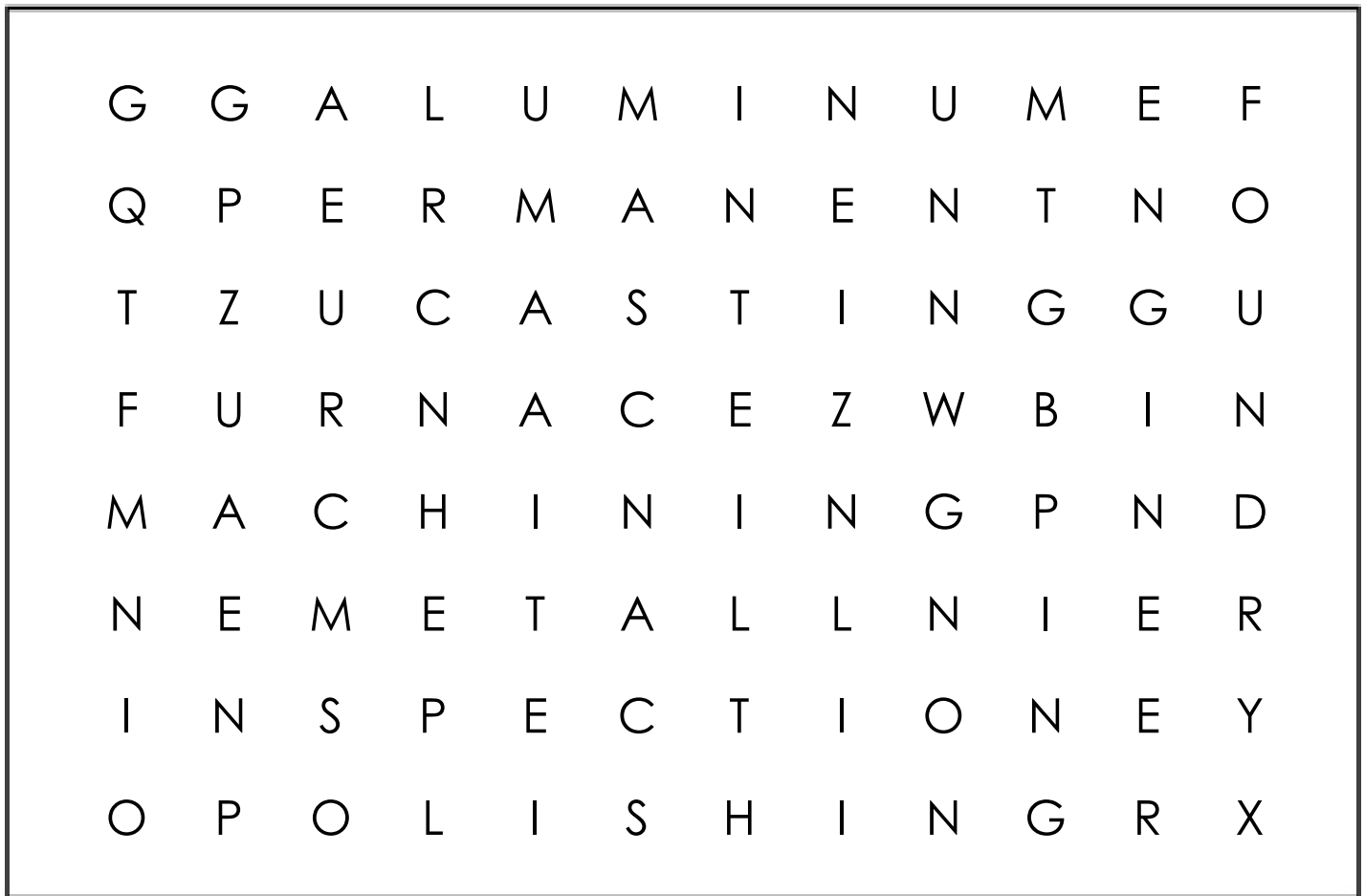

Find the following words in the puzzle.

Words are hidden → and ↓ .

ALUMINUM

BPI

CASTING

ENGINEER

FOUNDRY

FURNACE

INSPECTION

MACHINING

METAL

PERMANENT

POLISHING



# WORD SEARCH

Level 2

C	E	G	N	S	G	H	I	I	T	F	P	L	I	D	G	L	L
C	B	I	S	T	P	E	N	T	V	N	O	S	A	T	A	R	O
M	A	S	U	Q	E	B	S	K	L	M	L	U	M	J	Q	R	J
E	E	S	L	Z	R	I	P	G	S	A	I	P	N	J	C	A	M
T	T	G	T	V	M	O	E	I	J	C	S	F	F	D	P	K	P
A	Y	O	W	I	A	Z	C	P	H	H	H	W	F	C	R	W	T
L	Z	E	I	Y	N	A	T	V	O	I	I	E	P	V	A	Y	X
E	D	L	D	U	E	G	I	P	Y	N	N	R	Y	D	F	R	R
K	R	F	S	X	N	Z	O	B	A	I	G	M	M	O	L	D	U
O	H	X	A	W	T	J	N	U	T	N	G	H	F	H	Z	K	Q
N	F	U	R	N	A	C	E	U	R	G	J	O	Z	E	A	U	A
K	E	N	G	I	N	E	E	R	A	L	U	M	I	N	U	M	O

Find the following words in the puzzle.

Words are hidden → ↓ and ↘ .

ALUMINUM

BPI

CASTING

ENGINEER

FOUNDRY

FURNACE

INSPECTION

MACHINING

METAL

MOLD

PERMANENT

POLISHING





# CASTING

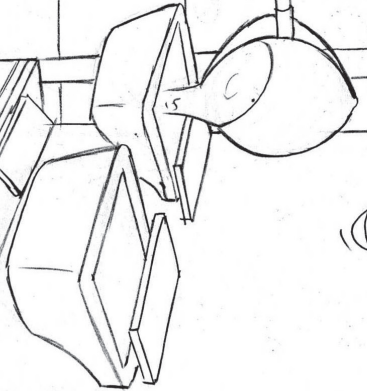
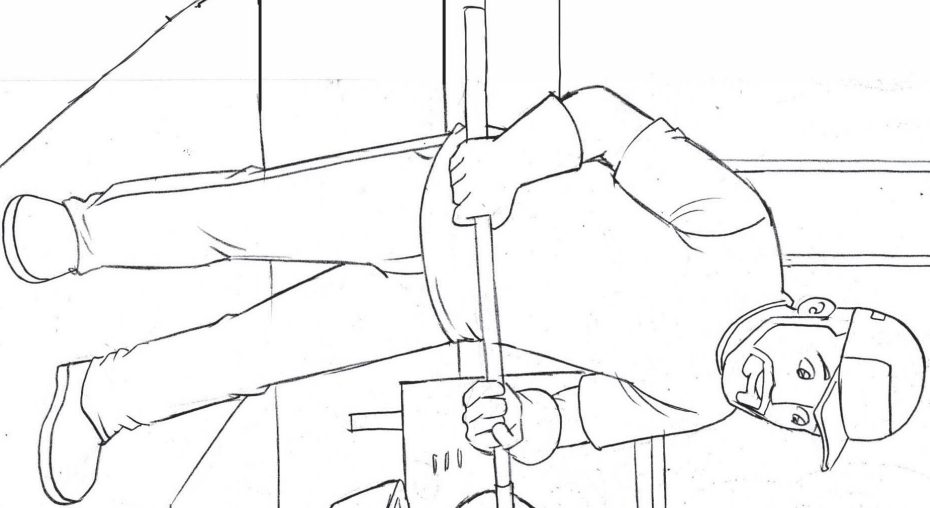

© Batesville Products, Inc.



# SPOT THE DIFFERENCE

1 of these 4 pictures is not like the others.  
Which one is different?



# ODD-ONE-OUT

Which of these is not like the rest?

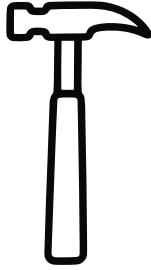

hammer



wrench



calipers



ball



safety glasses



winter hat



protective gloves



steel-toed boots



forklift truck



delivery truck

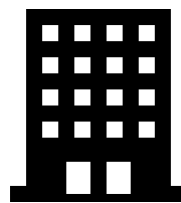

building



pallet jack



© Batesville Products, Inc.

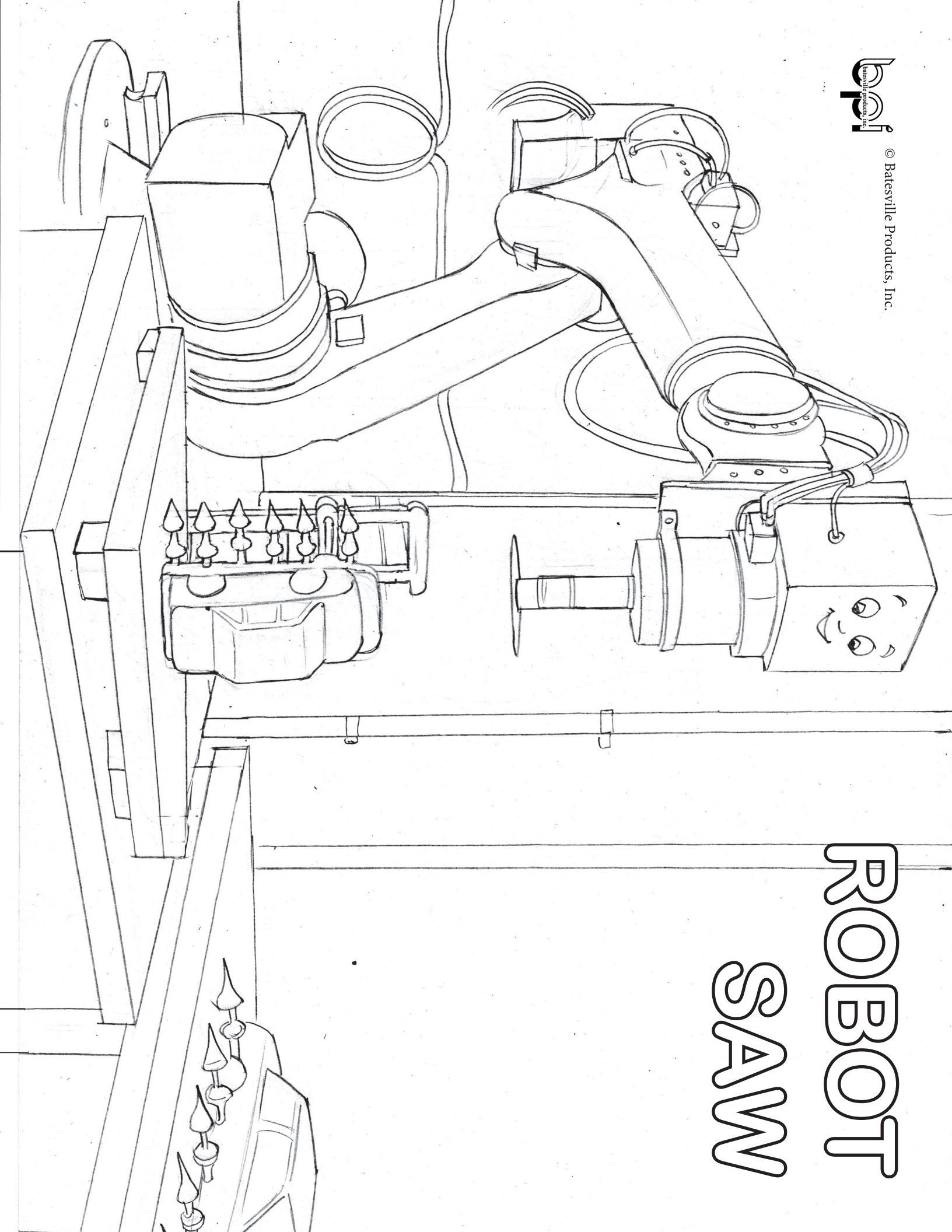

# ROBOT SAW

# MAD LIB

First, fill in the blanks, then read your story!

1. \_\_\_\_\_  
adjective

6. \_\_\_\_\_  
adjective

2. \_\_\_\_\_  
name

7. \_\_\_\_\_  
number

3. \_\_\_\_\_  
mode of transportation

8. \_\_\_\_\_  
emotion

4. \_\_\_\_\_  
past tense verb (ending in "ed")

9. \_\_\_\_\_  
color

5. \_\_\_\_\_  
number

10. \_\_\_\_\_  
food



## A Tuesday at Batesville Products (BPI)

On a warm and \_\_\_1\_\_\_ Tuesday, \_\_\_2\_\_\_ the engineer woke up late for work. He/She drove their \_\_\_3\_\_\_ as fast as he/she could and \_\_\_4\_\_\_ into BPI \_\_\_5\_\_\_ hours late! When \_\_\_2\_\_\_ got to work, no one else was there! So, he/she had to cast, machine, and polish \_\_\_6\_\_\_ castings all by themselves! After manufacturing \_\_\_7\_\_\_ castings, he/she was very \_\_\_8\_\_\_. It was finally time for lunch! \_\_\_2\_\_\_ took a big bite of \_\_\_9\_\_\_ \_\_\_10\_\_\_, his/her favorite food! *RING! RING!* Suddenly, \_\_\_2\_\_\_ woke up - It was only a dream!





# WORD SCRAMBLE

Unscramble the letters to make a word!

**LETTERS**

**WORD**

SHOILP

-----

FUNAMGCATNUIR

-----

REINGEEN

-----

BROOT

-----

GANTICS

-----

MAINULUM

-----

HAMNICE

-----

SPICENT

-----

*ANSWERS: POLISH, MANUFACTURING, ENGINEER,  
ROBOT, CASTING, ALUMINUM, MACHINE, INSPECT*



# MACHINING

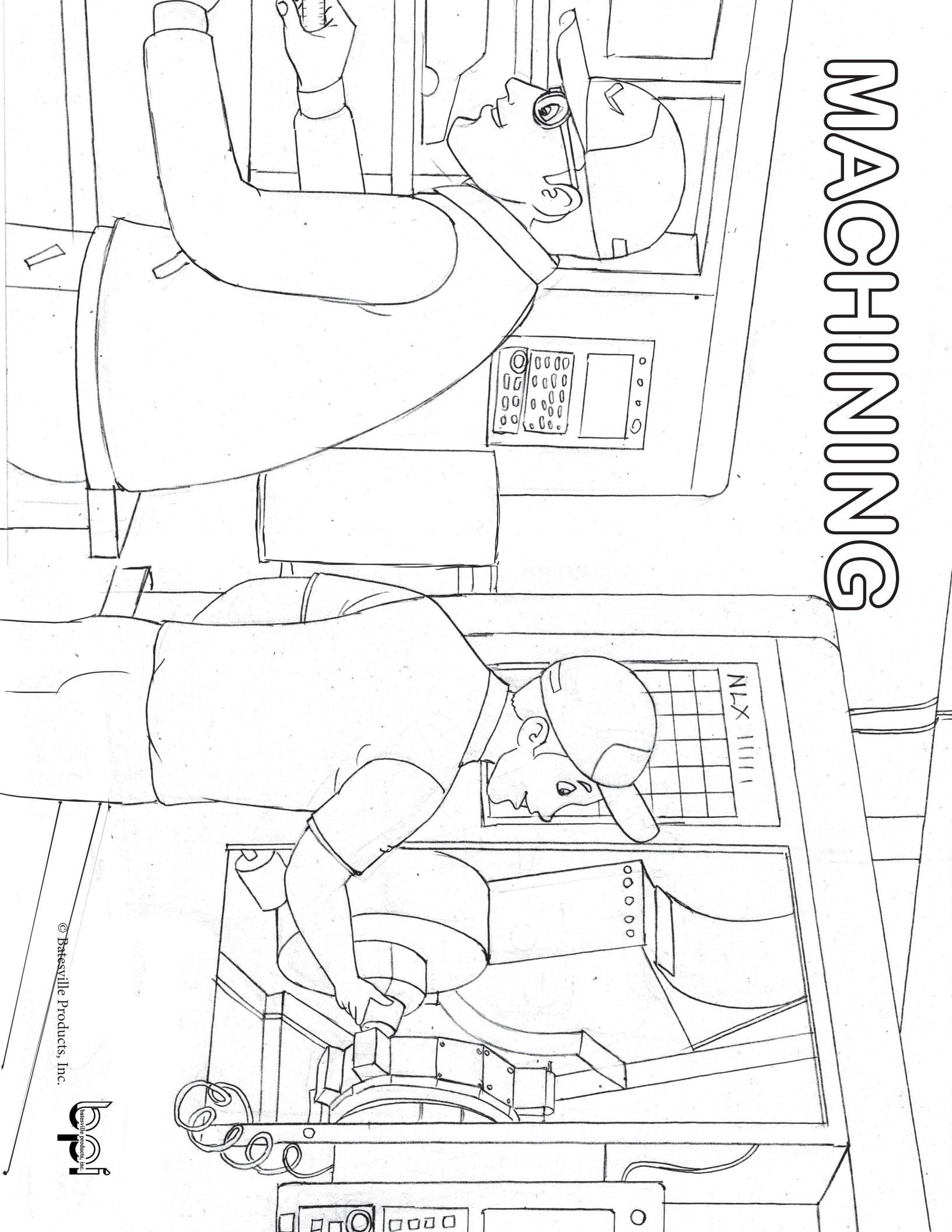

# COLOR SUDOKU

Color the squares so that each column, row, and corner box contains one red, one yellow, one green, and one blue square.

PUZZLE 1

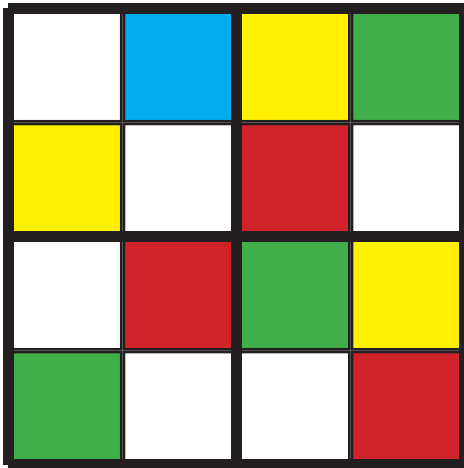

ANSWERS

R	B	Y	G
Y	G	R	B
B	R	G	Y
G	Y	B	R

PUZZLE 2

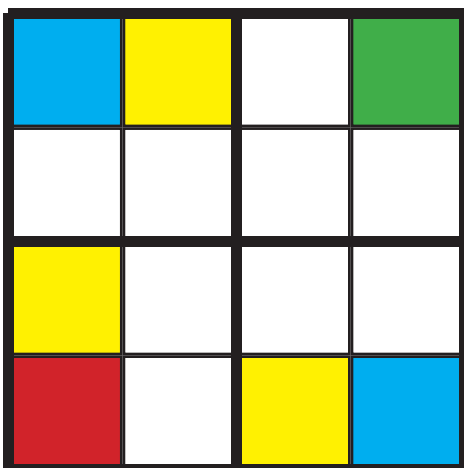

ANSWERS

B	Y	R	G
G	R	B	Y
Y	B	G	R
R	G	Y	B

# MAZE

Level 1

Help the truck deliver the castings!

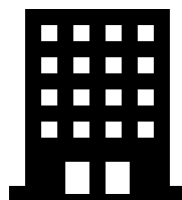
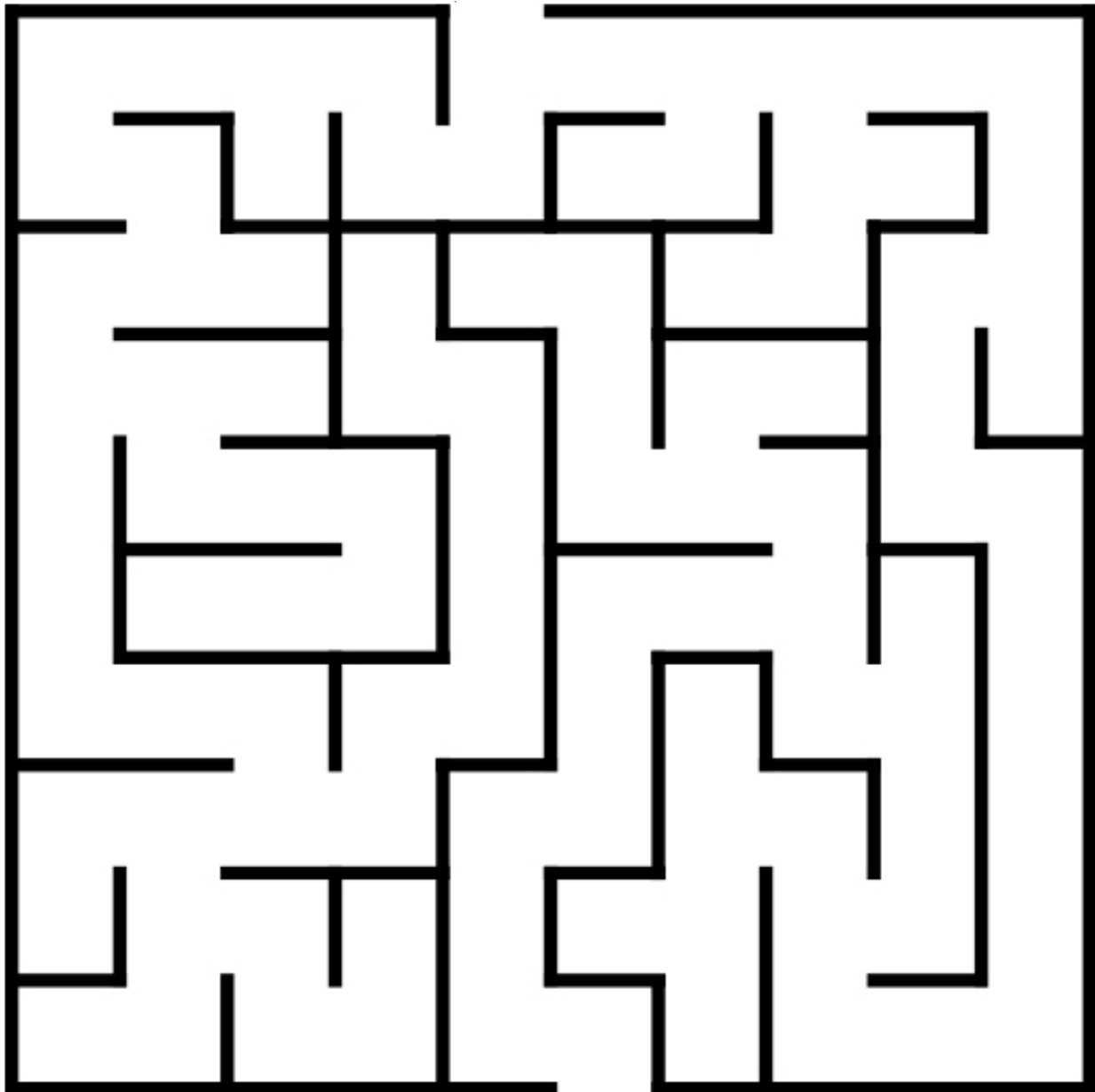



# MAZE

Level 2

Help the truck deliver the castings!

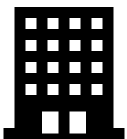
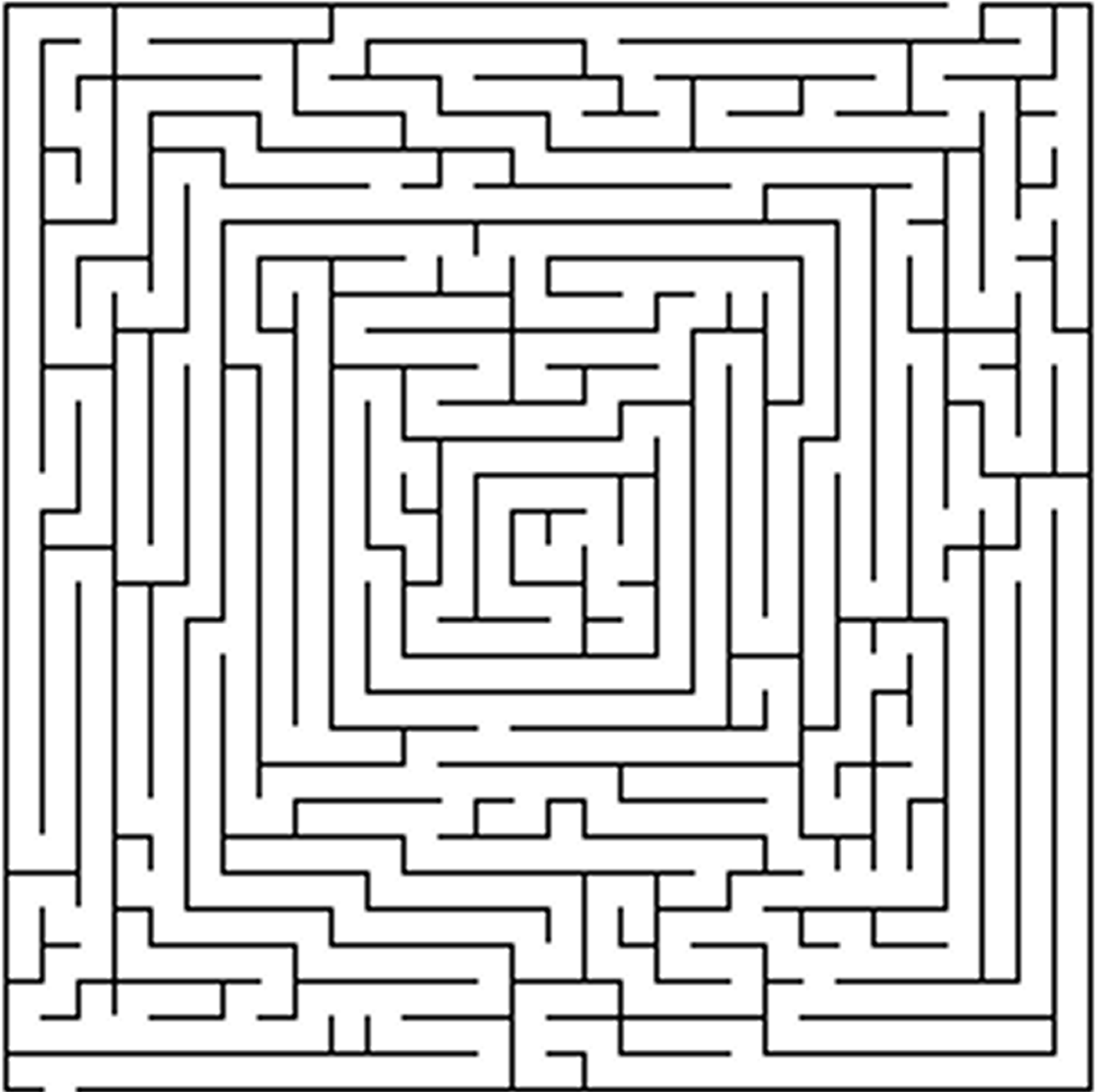

# POLISHING

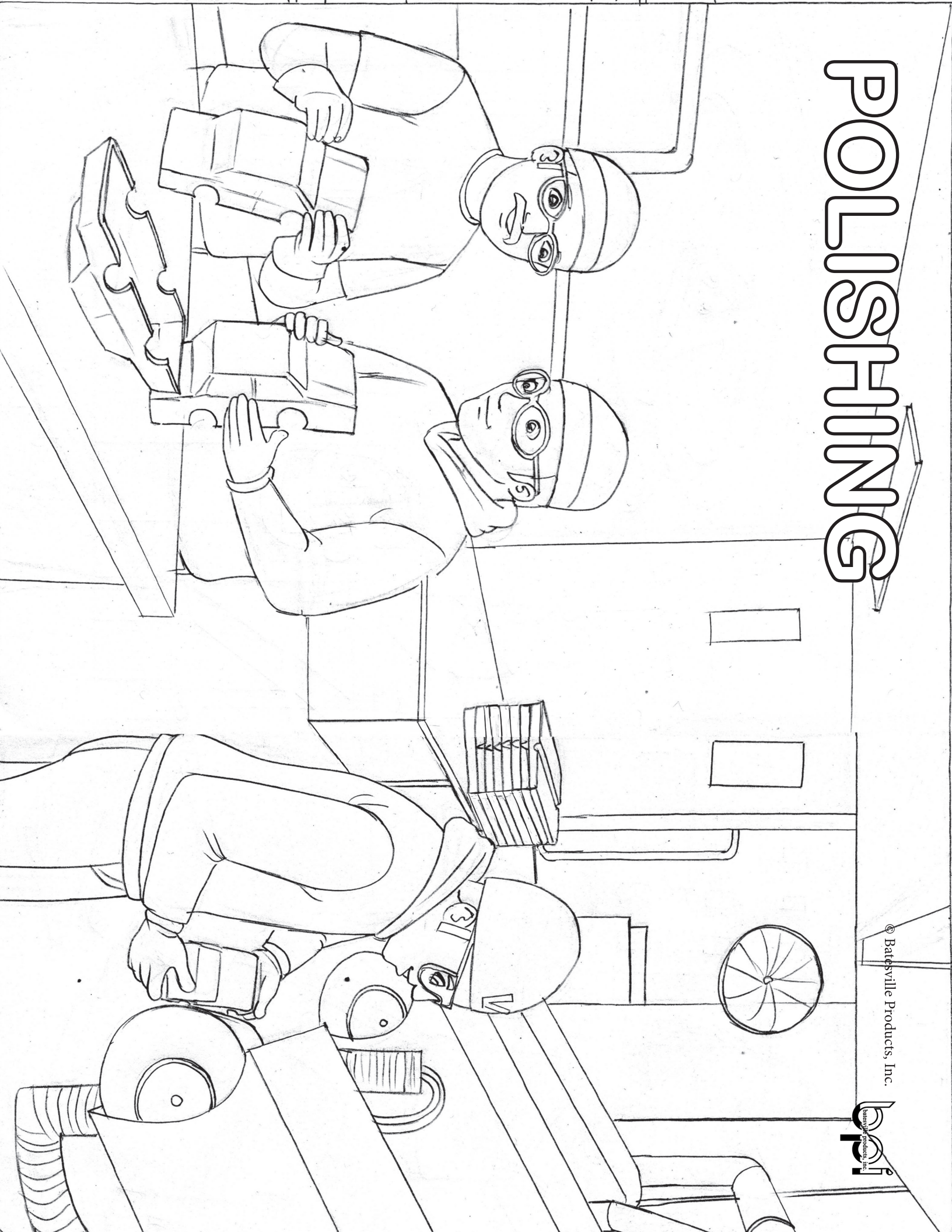

# MATCHING

Use the coloring pages in this book to match each person to their job!



**ENGINEER**

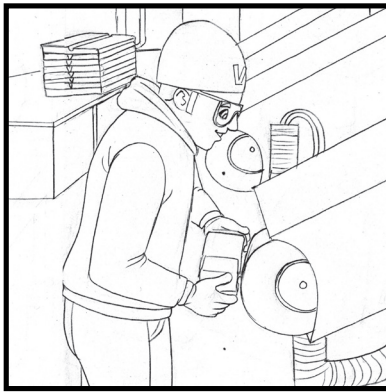

**CASTER**

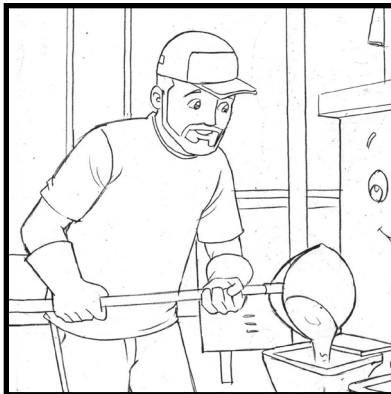

**MACHINIST**

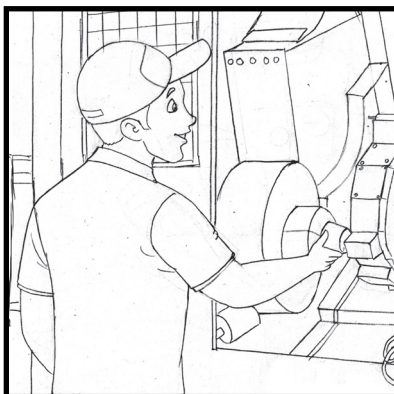

**POLISHER**





ROBOT SAW

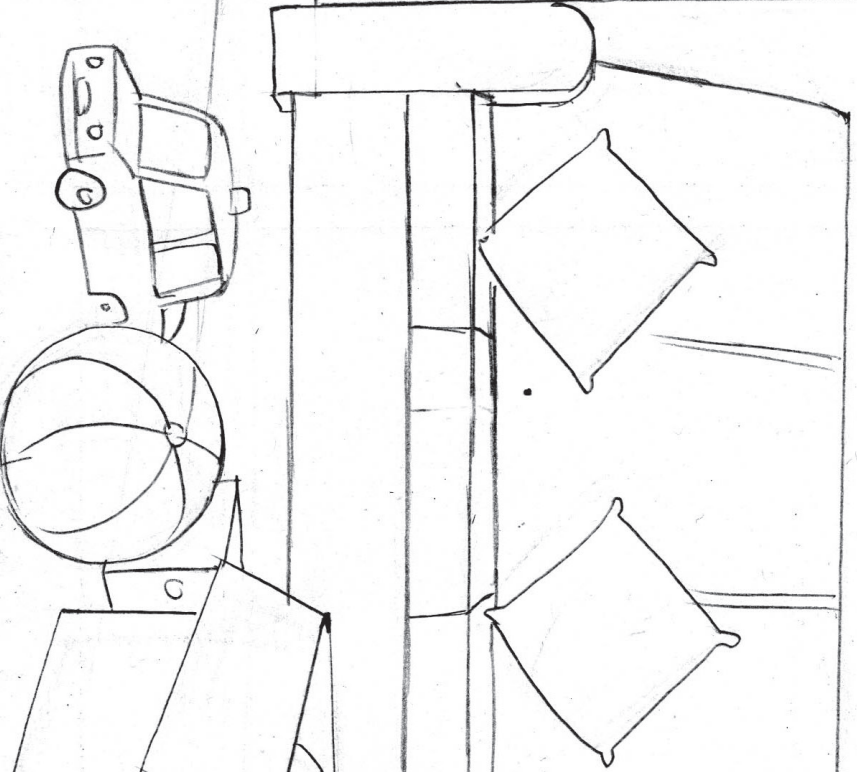
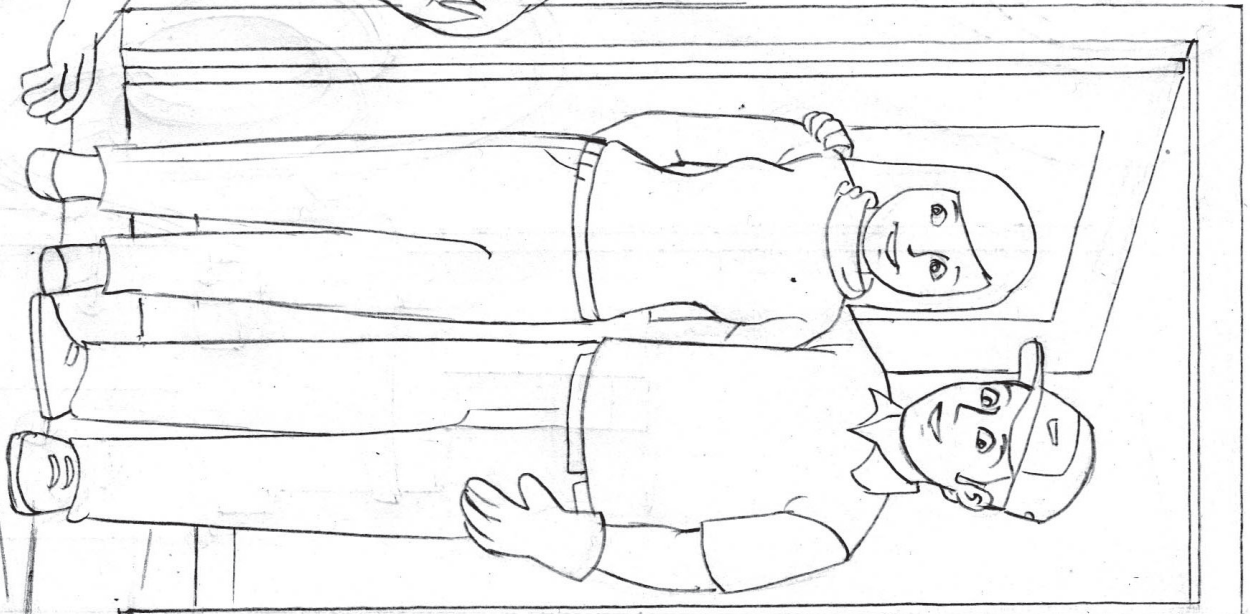
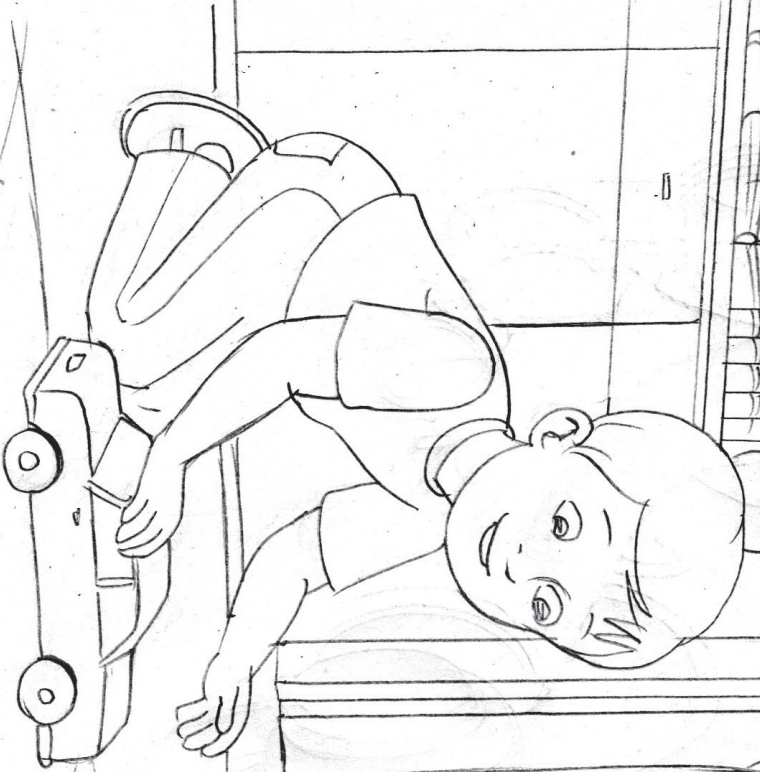
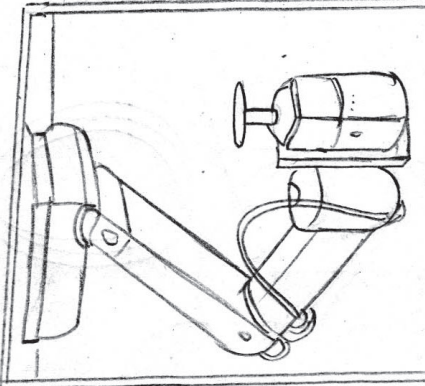

© Batesville Products, Inc.





# SOLIDIFICATION EXPERIMENT

MANUFACTURING SKILL: ENGINEERING & CASTING

When designing a casting, engineers pay attention to **solidification rate**, or how fast the melted aluminum turns into a solid casting. Most products we make go from molten metal to solid aluminum in 1-3 minutes!

## WHAT YOU'LL NEED

- Water
- 1 teaspoon of Sugar or Salt
- Vinegar
- Warm Coconut Oil
- 4 temperature-safe containers or an ice cube tray
- 1 Tablespoon or Measuring Spoon

**TRY THIS!**  
Get creative! Try freezing other liquids such as milk or dish soap!

## SET UP

In this activity, you'll observe 4 different materials changing from liquid to solid. Which one will solidify fastest? Which one will solidify slowest? Let's find out.

- 1** Mix 1 tablespoon of water with 1 teaspoon of sugar or salt until dissolved.
- 2** Fill your containers or ice cube tray with 1 tablespoon of each liquid. Put a different liquid in each compartment/container.
- 3** Place your containers in the freezer. Check after 1 minute, 5 minutes, 15 minutes and 30 minutes. Record when each liquid solidifies.

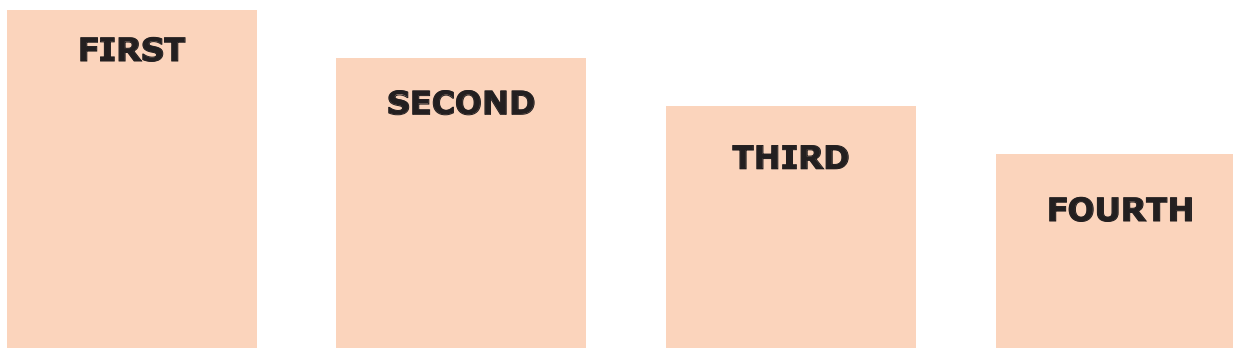

# DESIGN AN EDIBLE MOLD & CASTING

## MANUFACTURING SKILL: ENGINEERING & CASTING

*Our engineers help design permanent molds every day. This activity simulates "sand casting." This is a special type of metal casting process, similar to permanent mold casting.*

## WHAT YOU'LL NEED

- Brown sugar
- Chocolate
- A sea shell, toy, decoration, or other small 3D object to help you design your mold

## SET UP

You will use brown sugar to make a chocolate version of a small 3D object of your choice. The brown sugar will simulate a mold, and the chocolate will simulate molten aluminum. The amount of brown sugar and chocolate needed depends on the size of your object. For example, you only need about 1/4 cup brown sugar and 1/4 cup of chocolate chips to cast the foot print of a toy dinosaur!

- 1** Tightly pack brown sugar into a wide-mouthed, shallow container. You will need enough brown sugar to fit your object.
- 2** Clean your object with soap and water. Then, firmly press it into the sand. When you remove the object, it should have left an imprint in the sand. This will be your mold.
- 3** Break your chocolate into small pieces. Melt it in the microwave on a low setting, stirring frequently.
- 4** Once your chocolate is melted, carefully pour it into the cavity you created. Wait until it hardens. You can speed up the process by placing it in the fridge or freezer.
- 5** After the chocolate hardens, remove it from the brown sugar and enjoy your edible casting!

# SODA POP TILT-POUR PRESS

## MANUFACTURING SKILL: CASTING

When we make castings, we don't just dump the aluminum into a mold (and you'll see why after doing this activity!). We pour molten, liquid aluminum into a special machine called a tilt-pour press. This press controls the flow of the metal, so that it flows slowly without **turbulence** or air bubbles.

## WHAT YOU'LL NEED

- 2 carbonated drinks (*soda pop or sparkling water/juice*)
- 2 see-through cups
- A friend to share a drink with!

## SET UP

You will do 2 experiments that simulate casting with and without a tilt pour press. The carbonated drinks will symbolize your molten aluminum, and the cups will symbolize your permanent mold.

**1** First, we will simulate pouring aluminum without a tilt pour press. Set your first cup flat on a table or in a sink. Open the first carbonated drink. Aiming for the center of the bottom of the cup, turn the drink completely upside down, dumping it into the cup. You may need to stabilize the cup with your second hand. In the casting industry, this is what we call a *dump* or *static pour*. Notice the amount of bubbles and foam in the cup.

**2** Now, we will simulate pouring aluminum with a tilt-pour press. In this simulation, one of your hands will act as the tilt-pour press. This hand will hold the cup at an angle and slowly tilt the cup while you pour the drink. Open the second carbonated drink. Hold the cup horizontally, so the opening of the cup is perpendicular with the ceiling. Very *slowly* begin to tilt the cup upright. As you tilt, pour the drink in the cup, aiming for the side of the glass. The cup should not reach its normal upright position until you are done pouring the drink. Notice that the cup has less bubbles and foam than the first cup did.

## WHAT HAPPENED?

By pouring the drink down the side of the cup, you decreased *turbulence*. This means you decreased air bubbles and foam. When we pour castings, we try to avoid air bubbles. We call this *porosity*. Porosity makes castings weaker and harder to machine, and it allows gas and fluids to leak from the part.

# EDIBLE PERMANENT MOLD CASTING

## MANUFACTURING SKILL: CASTING

*When we make castings, we pour 1350 degree molten aluminum into steel permanent molds. In this activity, your gelatin dessert will simulate molten aluminum. Your flexible/nonstick kitchen container will simulate a steel permanent mold. Now let's make an **edible** casting!*

## WHAT YOU'LL NEED

- 1 3oz packet of gelatin dessert (example: Jell-O)
- 1 cup of boiling water
- A flexible/nonstick kitchen container (silicon mold, silicon muffin cups, ice cube trays, etc.)
- **OPTIONAL:** cooking spray

**1** First, mix 1 cup of boiling water with the gelatin packet. Stir for 2 minutes or until completely dissolved.

*Tip: This recipe probably doesn't follow the gelatin packet instructions, but there's a reason! If you add too much water and your casting will lose density (and fall apart!).*

**2** We prepare our steel permanent molds by preheating and coating them. We suggest you lightly coat your "permanent mold" (kitchen container) with cooking spray.

**3** Ladle or pour your "molten aluminum" (gelatin and water mixture) into your mold. Place the filled mold in the fridge for 4-5 hours, or until completely set.

**4** After 4-5 hours, flip the mold upside down and gently press on it until your casting plops out! Next, our castings are typically sawed, machined, inspected, and polished, but yours are ready to eat. Enjoy!

*Tip: If you have trouble removing the gelatin, try running warm water over your mold.*

### **TRY THIS!**

*Get creative! You can cast anything! Try replacing your molten aluminum to make custom chocolates, popsicles, hard candy, gummies, frozen yogurt, ice cubes, candle wax, crayons, soap bars, resin decorations, etc.*



# CNC MACHINING

CNC machines cut and drill castings. They make sure the same exact spot is cut on each casting. The CNC machine does this by picking out specific points on the casting, called *datum points*. Below are 31 different datum points. Can you draw or cut along the points to reveal a picture? Start with #1 and work your way up.

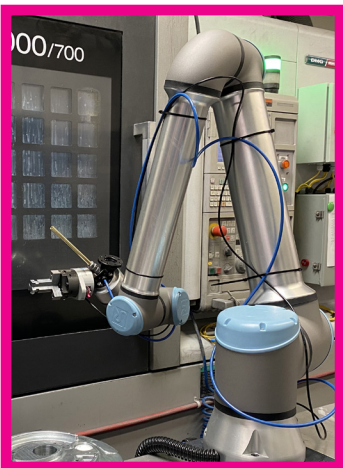
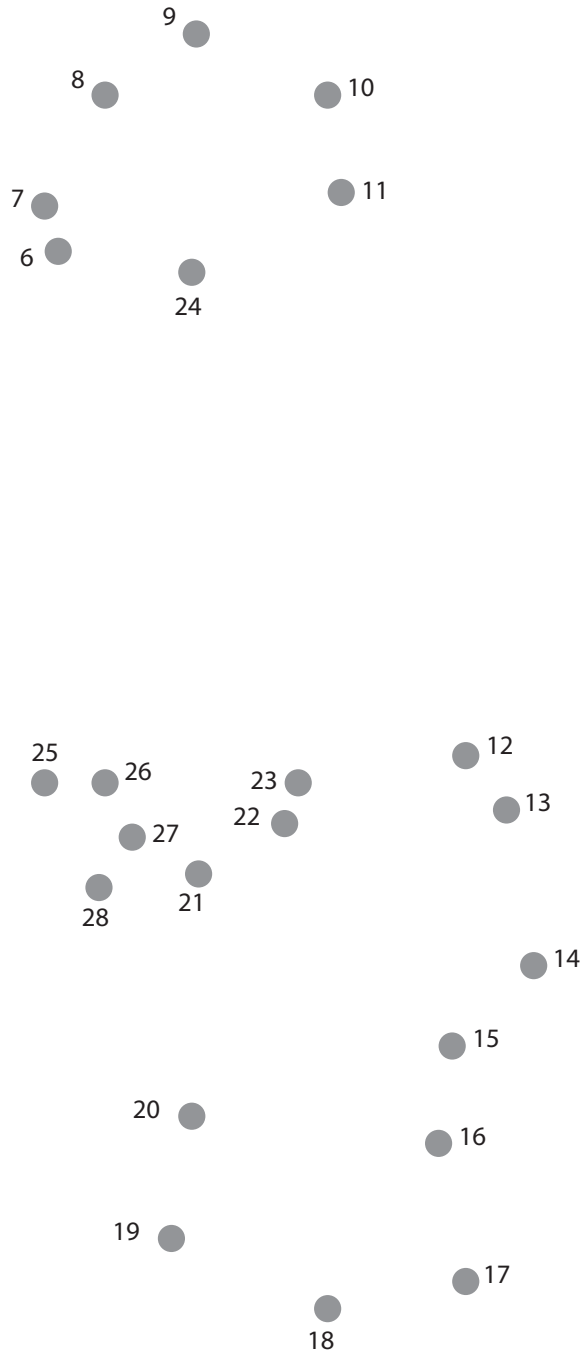

You made a **cobot**! A cobot is a *collaborative robot*. That means they are safe robots that work side by side with people. This particular cobot is programmed to load and unload parts into CNC machines at BPI.

© Batesville Products, Inc.



# CNC MACHINE: IDENTICAL CASTINGS

## MANUFACTURING SKILL: MACHINING

*CNC machines cut and drill castings. They make sure the same exact spot is cut on each casting, so the parts are identical. In this activity, you'll use scissors to make identical paper "castings."*

## WHAT YOU'LL NEED

- Scissors

**1** Cut along the dashed line on the right.

**2** Hold your paper strip landscape, with the triangle on the right and the gear on the left. Fold it in half. The right top corner should match the left top corner. The right bottom corner should match the left bottom corner.

**3** Separate the top layer from the bottom. Fold it in half towards the new crease you made (fold the left top corner to the right top corner, and the left bottom corner to the right bottom corner). The star and gear should now be showing.

**4** Now we will fold the bottom layer. Flip the paper over, so the star and gear are facing the table. Now fold the layer towards the crease (fold the top right corner to the top left corner, and the bottom right corner to the bottom left corner). The gear should be showing.

**5** Now cut around the gear. Be careful to avoid the edges that say "DO NOT CUT."

**6** Unfold the paper to reveal your identical "castings"!

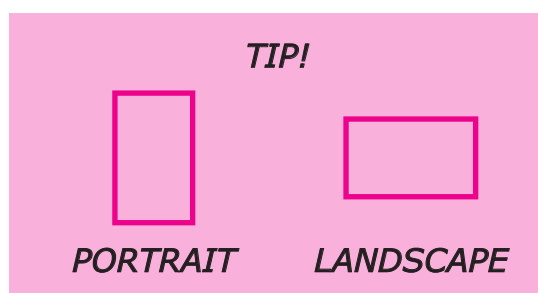



FOLD LINE

FOLD LINE

CUT THIS DASHED LINE

FOLD LINE

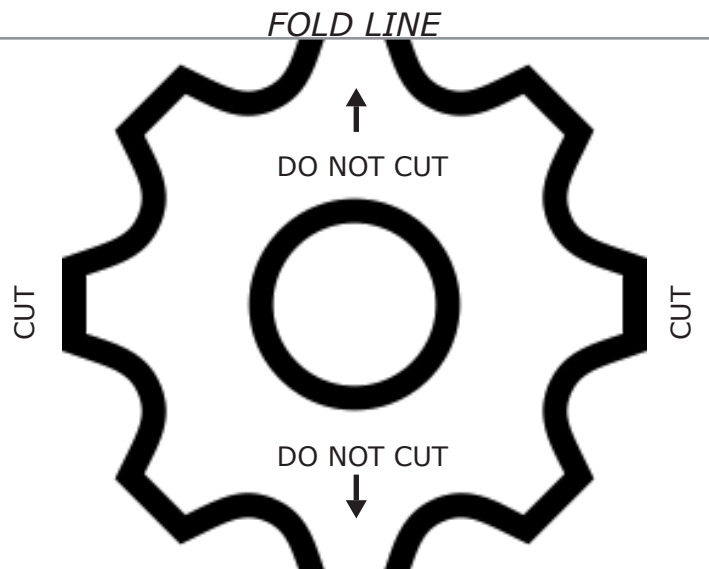

# EXPLORE RATIOS: INSPECT & MEASURE

## MANUFACTURING SKILL: MACHINING

*After we make a casting, we measure it and inspect it. We want each part to look similar and be exactly the same size. Like identical castings, did you know that the human body naturally has parts that are the same measurements? In this activity, you'll measure different parts of your body to explore naturally occurring ratios!*

## WHAT YOU'LL NEED

- A flexible measuring tape OR a long piece of string

## SET UP

Use the measuring tape or string to inspect these measurements...

**1** Does your **height** = your **arm span** (*the distance between the middle fingertips on each hand when you stretch your arms out as far as they can reach*)?

**2** Does your **height** = 4 of your **femur bones**? To measure your femur, sit down and measure your thigh from the hip joint to the edge of your knee.

**3** Does your **foot** = your **forearm** (*the distance between your elbow and wrist*)?

**4** Does the circumference of your **neck** = the circumference of your **hands**? Put your thumbs together. Can you wrap your hands around your neck, with your middle finger tips touching?

**5** Does the circumference of your **wrist** = the circumference of one **hand**? Can you wrap your hand around your wrist, with the thumb and middle finger touching?

## WHAT HAPPENED?

Typically, the measurements listed above are similar. But what if they aren't? That means you're probably still growing! On average, humans don't stop growing until the age of 18!



# PENNY POLISHING

## MANUFACTURING SKILL: POLISHING

*Polishers make castings smooth and shiny but rubbing them hard with course, rough belts, similar to sand paper. In this activity, you can polish a coin in a similar way - by rubbing it with an **abrasive** material.*

## WHAT YOU'LL NEED

- A dirty coin (*penny, nickel, dime, quarter, etc.*)
- A soft eraser (*either on a pencil, or a large one*)
- A piece of scrap paper

**1** Lay your dirty coin on a piece of scrap paper. The paper will catch all your eraser shavings, for easy clean up. Hold the coin with one hand. With the other hand, rub the pencil eraser over the coin in small, circular motions.

**2** Once it is clean and shiny, flip the coin and work on the other side. Now you have a shiny coin!

---

## WHAT YOU'LL NEED

- A dirty coin (*penny, nickel, dime, quarter, etc.*)
- 2 tablespoons of baking soda
- A splash of water
- A small bowl
- An old cloth

**1** In a small bowl, mix 2 tablespoons of baking soda with a little bit of water until you form a paste.

**2** Place some of the paste on an old cloth. Rub the coin with the paste in circular motions.

# FINGERNAIL BUFFING

## MANUFACTURING SKILL: POLISHING

*Polishers "buff," or make castings shiny by rubbing them with a combination of grit belts. First, they rub them with really rough, abrasive belts. Then they change belts. The last belt they use is soft like cotton! In this activity, you will use various rough and soft fabrics to buff your fingernails in a similar way - until they are smooth and shiny!*

## WHAT YOU'LL NEED

- Denim (*jeans or jacket*)
- Flannel (*shirt, socks, pajamas*)
- Fleece (*blanket, pajamas, jacket*)
- Cotton T-shirt
- Piece of Paper

*Tip: Don't have everything? That's okay! Just use what have and skip the steps with things you don't have.*

- 1** Using circular motions, rub your fingernail with a piece of denim for about 4 seconds. This is the roughest material we will use.
- 2** Using circular motions, rub your fingernail with a piece of flannel for about 4 seconds. This is another rough material.
- 3** Using circular motions, rub your fingernail with a piece of fleece for about 4 seconds. This material is a medium roughness.
- 4** Using circular motions, rub your fingernail with a piece of cotton for about 4 seconds. This is another softer material.
- 5** Using circular motions, rub your fingernail with a piece of paper for about 4 seconds. This is the softest material we will use.
- 6** Now your fingernail should be smooth and shiny! Apply lotion to enhance the look.

# WHAT'S YOUR FAVORITE ACTIVITY?

If you liked the **orange** activities the best, then you might want to be an **engineer** when you grow up!



**ENGINEER**

If you liked the **blue** activities the best, then you might want to be a **caster** when you grow up!



**CASTER**

If you liked the **pink** activities the best, then you might want to be a **machinist** when you grow up!



**MACHINIST**

If you liked the **green** activities the best, then you might want to be a **polisher** when you grow up!

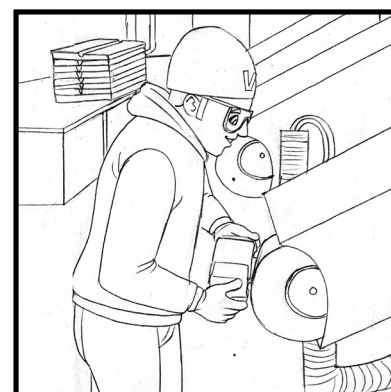

**POLISHER**

*All activities described in this publication, Manufacturing Experiments, are activities that the authors feel are safe for school-aged children (8 and up), but only with appropriate adult supervision and assistance. All activities described in this publication are intended to be performed with adult supervision and assistance. Parents, guardians and teachers are advised to use discretion in assisting children with these activities. Appropriate and reasonable caution should be used when activities call for the use of materials that could potentially be harmful, such as scissors, boiling water, cooking spray, and/or any food items that a child could be allergic to. Observe caution and safety at all times.*

*Appropriate safety gear, including eye protection, should be worn at all times. Batesville Products, Inc. disclaims any and all liability or responsibility for any damage, mishap, or injury that may occur from engaging in any of these activities in this publication. © Batesville Products, Inc.*

# EXPLORE MANUFACTURING!

COLLECT  
THEM ALL!



Story book, magnet, stickers, experiment book, level 1 activity book, level 2 activity book, coloring book!



Watch videos and learn more about  
American manufacturing on the  
Batesville Products website!

